

Gouging Torch/ Gouging Electrode Holder

M/ GT Series



Model M Series	Model GT Series	Max. AMPS	Max. Carbon
M - I	GT - 601	600 Amps	9 mm Ø Carbon
M - 801	GT - 801	800 Amps	10 mm Ø Carbon
M - 1001	GT - 1001	1000 Amps	12 mm Ø Carbon
M - II	GT - 1201	1200 Amps	16 mm Ø Carbon
M - III	-	1800 Amps	19 mm Ø Carbon

EQUIPMENT-POWER

An ordinary Arc Welding machine, DC Motor Generator or Engine Driven Welder and Air Compressor capable of giving a pressure of 80/125lbs PSI will be required for using the *metal arc*® Torches.

OPERATION

1. The current cables from the power supply should be of adequate capacity, free of joints, kinks and insulation damages.
2. The compressed air line is to be firmly attached onto the air connection nipple and the joint should be free of leaks.
3. Set the correct amperage in accordance with the diameter of electrode being used as per recommended currents (table I given on page 5).
4. Turn on the compressed air supply and open the air valve on the Torch fully.
5. Turn on the current supply.
6. Strike the arc on the job and maintain adequate arc gap. Adjust hand travel speed to produce continuous hissing sound for smooth cutting action.
7. To shut down, turn off electrical power first.
8. Turn off air supply after electrical power is shut down.

AIR SUPPLY

An ordinary air compressor can be used. Most applications require 80 to 100 lbs PSI air pressure. For higher duty torches 80 PSI may be adequate. Heavy Duty Torches would require as much 125 lbs PSI. Air hose should have a minimum base of ¼ inches diameter.

NOTE: The above data is based on the following conditions and should be considered only as a general guide: -

Electrode stick out	90 mm	Air pressure	80/100 lbs PSI
Torch to west angle	45°	Arc Volts	35 to 45 volts



Gouging Torch/ Gouging Electrode Holder

The recommended current ranges for various carbon arc cutting electrodes are **INDICATIVE ONLY** below: - Specification of Round Copper-Coated Gouging Carbon Electrode (D.C.)

Dia X Length		Current Range(A)	
mm	inches	To	From
4 X 305 (355)	5/32 X 12' (14')	240	300
6 X 305 (355)	15/64 X 12' (14')	360	410
9 X 305 (355)	23/64 X 12' (14')	540	600
12 X 305 (355)	15/32 X 12' (14')	720	840
13 X 305(355) (430) (510)	½ X 12' (14')(17') (20')	780	920
16 X 355 (430) (510)	5/8 X 14' (17') (20')	960	1100
19 X 355 (430) (510)	¾ X 14' (17') (20')	1150	1300
25.4 X 355 (430) (510)	1 X 14' (17') (20')	1525	1800

MAINTENANCE AND TROUBLE SHOOTING:

A. Maintenance:

1. Check cables and hoses for damage, kinks and joint leaks.
2. Check all screwed connections at the Torch, Power Supply and supply lines.
3. Check Air holes on Swivel Head on Torch; change Swivel head if necessary, or clean air holes.
4. Check grip on electrode; change spring if necessary.
5. Check air control valve for any damage.

B. Trouble Shooting:

S. No.	Trouble	Cause	Solution
1.	Hard, irregular start	No air supply	Open air valve on torch before the start.
2.	No arc	No/ low current	Check power source, current cables and torch.
3.	Sputtering mild arc	Low current	Increase Current setting on power source.
4.	Irregular cut	Electrode Touching	Maintain arc gap
		Loose Connections	Check connections.
5.	Slag adhering to edges of cut.	Insufficient air supply	Check air holes and valve. Reduce Electrode stick out. Check air pressure

Direct current reverse polarity is used for most applications. However A.C. also can be used and the electrode for the same is being developed. On some metals D C straight polarity is preferred. The table below indicates the most suitable Electrode, Current and polarity for various materials in order of preference:

Table II

Material	Electrode	Current	Polarity
Steel	DC	DC	Reverse
Stainless	AC	AC	
	DC	DC	Reverse
Iron (Cast) (Ductile and Malleable)	AC	AC	
	DC	DC (high amp)	Reverse
Copper alloys	AC	AC or DC	Straight
	DC	DC	Reverse
Nickel alloys	AC	AC or DC	Straight
	AC	AC or DC	Straight

B. R. Kumar & Sons

499 Haveli Haider Kuli, Chandni Chowk, Delhi 110006

E-mail: sales@metalarc.in/ sales.west@metalarc.in

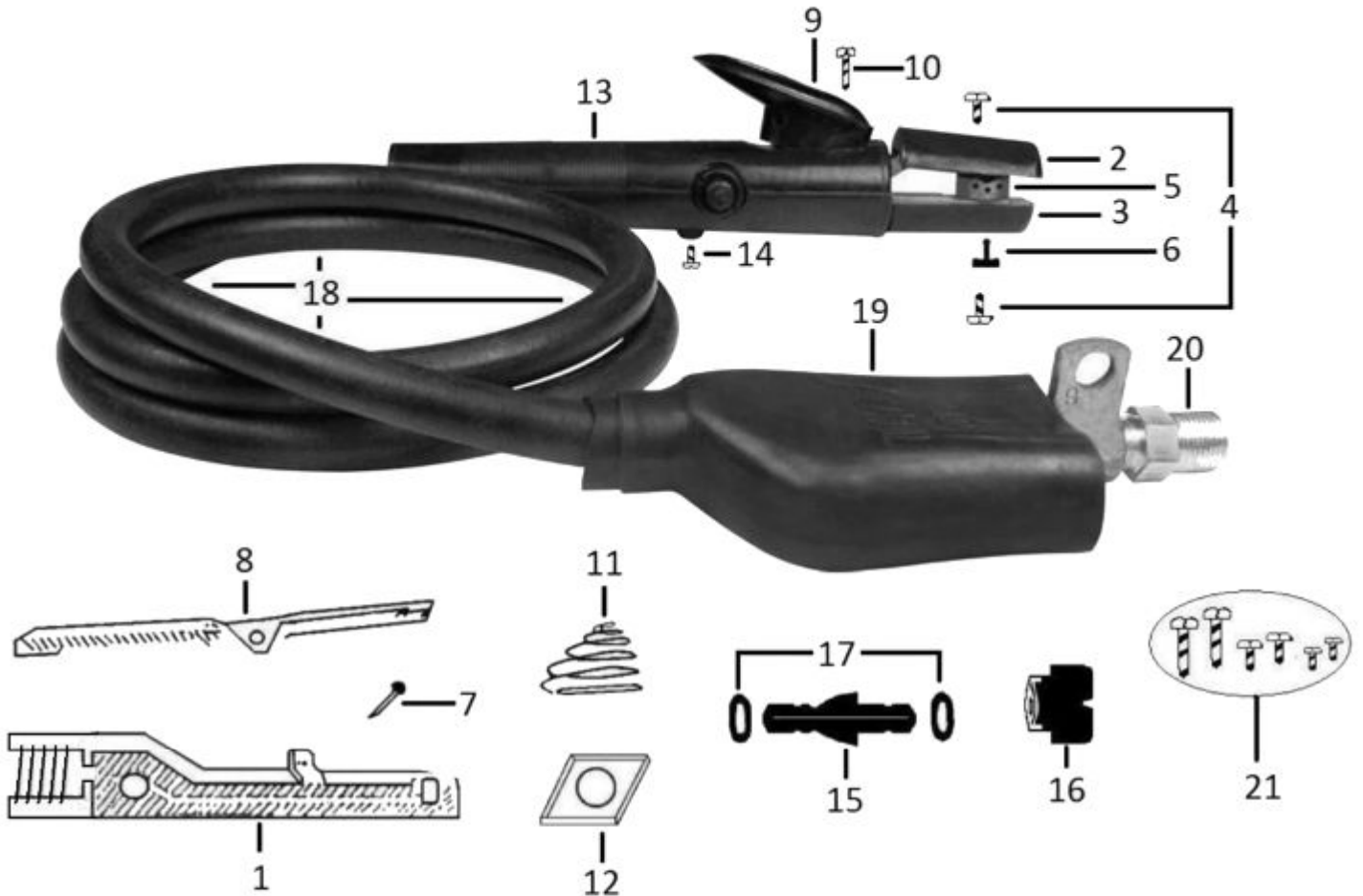

Spares for M/ GT Series

Part No.	Item	No. of Pcs/ Torch	Part No.	Item	No. of Pcs/ Torch
1	Body	1	12	Lever Base	1
2	Upper Hood Cover	1	13	Handle	1
3	Lower Hood Cover	1	14	Screw for Body/ Handle	1
4	Screw for Hood Covers	1 Set	15	Air Control Valve	1
5	Swivel Head	1	16	Valve Cap	1
6	Screw for Swivel Head	1	17	Rubber O Ring	1 Set
7	Dowel Pin	1	18	Coaxial Cable Assembly	1
8	Upper Arm Clamp	1	19	Insulator Boot	1
9	Clamp Lever Handle	1	20	Air Control Adapter	1
10	Screw for Clamp Lever Handle	1	21	One Complete Set Of Screw	1
11	Spring	1	1 Set = 2 Pieces		

- ✓ Parts highlighted in BLUE are recommended
- ✓ Special offer when placing MOQ: 30 Pieces and above
- ✓ Special offer when placing order with Gouging Torch MOQ: 10 Pieces and above